

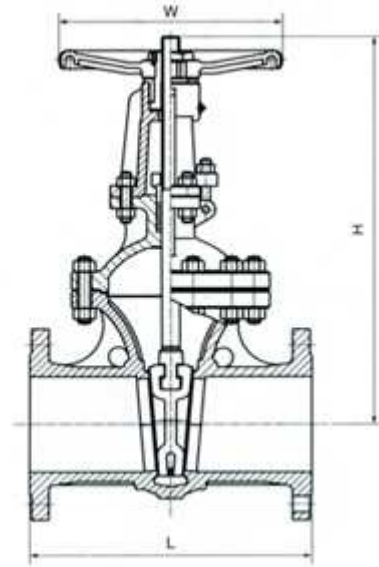

**DIN F7 RISING STEM GATE VALVE**



Features:

**DIN F7 RISING STEM GATE VALVE**

**Technical specification**

Structural Formation	BB-BG-OS & Y
Driving Manner	Hand-Operated
	Electric-Actuated
Design Standard	DIN3352
Face to Face	DIN3202
Flange Ends	DIN2543-2547
Test & Inspection	DIN3230

Notes: The size of serial, valve connecting flange can be design according to customers requirment.

**Products performance specification**

Nominal Pressure (Mpa)	Shell Test(Mpa)	Sealing Test(Mpa)	Suitable Temp(oC)	Suitable Medium
1.6	2.4	1.76	-110~600 oC	Water Oil & Gas
2.5	3.75	2.75		



4.0	6.0	4.4		
6.4	9.6	7.04		

**Main Dimensions**

**unit:mm**

Pressure (Mpa)	PN 4.0 Mpa													
	Size	50	65	80	100	125	150	200	250	300	350	400	450	500
L	250	290	310	350	400	450	550	650	750	850	950	1050	1150	1350
H	404	456	604	607	720	780	875	1260	1480	1605	1788	1956	2168	2601
W	200	280	300	350	350	400	450	500	500	600	650	700	700	800
Weight(kg)	18	32	47	60	95	130	220	290	490	760	900	1250	1450	1700

Pressure (Mpa)	PN 6.4 Mpa													
	Size	50	65	80	100	125	150	200	250	300	350	400	450	500
L	250	290	310	350	400	450	550	650	750	850	950	1050	1150	1350
H	404	456	604	607	720	780	875	1260	1480	1605	1788	1956	2168	2601
W	200	280	300	350	350	400	450	500	500	600	650	700	700	800
Weight(kg)	20	35	52	66	103	140	230	300	510	780	940	1300	1600	1850